

Loughborough University  
Institutional Repository

---

*Solvent resistant  
nanofiltration: developing  
understanding of transport  
mechanisms*

This item was submitted to Loughborough University's Institutional Repository by the/an author.

**Citation:** TARLETON, E.S. and ROBINSON, J.P., 2006. Solvent resistant nanofiltration: developing understanding of transport mechanisms. International Workshop: Membranes in Solvent Filtration, 23-24 March, Leuven, Belgium, Paper 14.

**Additional Information:**

- This is a conference paper.

**Metadata Record:** <https://dspace.lboro.ac.uk/2134/4943>

**Version:** Accepted for publication

**Publisher:** VITO NV and KU Leuven

Please cite the published version.

This item was submitted to Loughborough's Institutional Repository (<https://dspace.lboro.ac.uk/>) by the author and is made available under the following Creative Commons Licence conditions.



CC creative commons  
COMMONS DEED

**Attribution-NonCommercial-NoDerivs 2.5**

**You are free:**

- to copy, distribute, display, and perform the work

**Under the following conditions:**

 **Attribution.** You must attribute the work in the manner specified by the author or licensor.

 **Noncommercial.** You may not use this work for commercial purposes.

 **No Derivative Works.** You may not alter, transform, or build upon this work.

- For any reuse or distribution, you must make clear to others the license terms of this work.
- Any of these conditions can be waived if you get permission from the copyright holder.

**Your fair use and other rights are in no way affected by the above.**

This is a human-readable summary of the [Legal Code \(the full license\)](#).

[Disclaimer](#) 

For the full text of this licence, please go to:  
<http://creativecommons.org/licenses/by-nc-nd/2.5/>

## SOLVENT RESISTANT NANOFILTRATION: DEVELOPING UNDERSTANDING OF TRANSPORT MECHANISMS

E.S. Tarleton<sup>1</sup> ([e.s.tarleton@lboro.ac.uk](mailto:e.s.tarleton@lboro.ac.uk)) and J.P. Robinson<sup>2</sup>

<sup>1</sup>Advanced Separation Technologies Group, Department of Chemical Engineering, Loughborough University, Loughborough, Leics., LE11 3TU, UK.

<sup>2</sup>now at School of Chemical, Environmental and Mining Engineering, University of Nottingham, Nottingham, NG7 2RD, UK.

### ABSTRACT

In recent years the possibility of using polymeric nanofiltration (NF) membranes for non-aqueous separations has been explored. There is, however, significant debate concerning fundamental mechanisms where concepts include solution-diffusion and 'pore' flow. This paper presents nanofiltration and swelling data for polyacrylonitrile (PAN)/poly-dimethylsiloxane (PDMS) composite membranes with a range of low and higher polarity solvents, some of which contained solutes in the range 84-612 MW. The influences of parameters such as crossflow rate, applied pressure, solute size and solvent polarity on filtration performance are presented and measures of flux and solute rejection are related to membrane swelling. More comprehensive descriptions of the experimental apparatus and results are shown in [1-7].

### EXPERIMENTAL

The principal experimental apparatus used in the investigations are shown schematically in Figures 1 and 2. Flux and steady state rejection performance were determined using the apparatus in Figure 1 which operated with a standard DESAL membrane module (wetted area = 75 cm<sup>2</sup>) and crossflow rates up to 4 l/min. Measurements of solvent/solute rejection, as determined by UV-vis spectroscopy or refractive index, were typically repeatable within  $\pm 1\%$ . In determinations of membrane swelling (Figure 2), a *circa* 2 cm square sample of membrane was placed in a flat-bottomed dish, a 10 mm diameter spacer was placed on top of the sample and a linear measurement probe (resolution 0.1  $\mu\text{m}$ ) was positioned over the spacer and connected to an electronic column gauge. Subsequent introduction of 5 ml of solvent enabled the swelling of a membrane to be determined. With the addition of a support frame and cantilever bar that pivoted about a bearing mount in one end, it was possible to impose a pressure up to 2000 kPa upon a test sample.

A range of alkane (e.g. hexane, heptane and cyclohexane), aromatic (e.g. xylene) and alcohol (e.g. methanol, ethanol and propanol) solvents were used in the experiments. These span a range of polarity as evidenced by their solubility parameters  $\delta = 14.3\text{-}29.2 \text{ MPa}^{0.5}$ . All solvents had initial purities in excess of 99%. Fourteen solute compounds representative of poly-nuclear aromatic (PNA), organometallic (OM) and sulphur bearing compounds were used in the nanofiltration experiments, although the majority of data were obtained using a representative PNA (9,10-diphenylanthracene). Solute concentrations up to 75 ppm were chosen and all filtration experiments were performed using one litre of a solvent/solute mixture with a 10% stage cut.

A range of PAN/PDMS composite membranes were available. Each comprised of a  $\sim 40 \mu\text{m}$  PAN layer upon which a PDMS layer between 1 and 10  $\mu\text{m}$  was either dip or roll coated. The resultant composite was subjected to a radiation dose (50-200 kGy) and/or thermal step upon which different degrees of crosslinking could be imparted to the PDMS.

### RESULTS AND DISCUSSION

## Determinations of Swelling

Typical swelling data representative of all the tested membranes is shown in Figures 3 and 4; the length dimension on each line legend in Figure 3 represents the PDMS thickness before swelling commenced. For low polarity solvents the swelling was exclusively dictated by expansion of the PDMS, whereas with the highest polarity solvents shrinkage of the PAN substrate became progressively more comparable to dimension changes in the PDMS. By way of example, for the 80 kGy radiation, 2  $\mu\text{m}$  membrane and solvents with  $\delta$  values in the range 14.3-15.3  $\text{MPa}^{0.5}$ , the average expansion of the PDMS layer increased from 148% to 169% where the latter represents the peak value. Over the region  $\delta = 15.3\text{-}23.6 \text{MPa}^{0.5}$  the solvent polarity increases to induce progressively less swelling in the PDMS layer and for i-propanol the average expansion was limited to 14%. It is evident from Figure 3 that nominally similar PAN/PDMS composite membranes swell to significantly different extents dependent upon the mode of manufacture and there are no generally applicable values. Figure 4 shows that swelling of the PDMS layer on a membrane is generally restricted by an imposed pressure (e.g.  $\sim 20\%$  at 2000 kPa compared with  $\sim 115\%$  at 0 kPa) and that an increased fraction of alcohol in a solvent mixture also leads to reduced swelling.

## Effects of Crossflow Rate (Hydrodynamics)

The effects of hydrodynamics were investigated at a fixed pressure of 500 kPa and crossflow rates ranging from 0.1–4 l/min with 80 kGy radiation, 2  $\mu\text{m}$  membranes. Whilst the module design prevented the direct calculation of Reynolds Number (Re), the module dimensions were the same in each test such that flow velocity is proportional to crossflow rate and  $Q\rho/\mu$ , a similar expression to Re, can be used to compare rejection behaviour (see Figure 5);  $Q$  is the crossflow rate,  $\rho$  is solvent density and  $\mu$  is solvent viscosity. In all cases solute rejection increased as crossflow was raised, an effect also observed with other tested solutes. Above a threshold value of  $\sim 0.5$  l/min ( $Q\rho/\mu \approx 10 \text{ m}$ ), little increase in rejection was noted with n-heptane and xylene solvents up to the highest available crossflow of 4 l/min. Rejection behaviour with the cyclohexane solvent was intermediate between these two pure solvents whilst the n-heptane/xylene mixture, whose composition gave an identical solubility parameter of  $\delta = 16.8 \text{MPa}^{0.5}$ , overlaid the cyclohexane result; no separation of this binary mixture was recorded on passage through the membrane. The authors data for low polarity solvents suggest that solvent flux can be directly related to membrane swelling and the relative magnitude of  $\delta$  for the permeating solvent and membrane. Solvents inducing a larger amount of swelling yield higher fluxes and lower solute rejection than poorer swelling solvents. The solubility parameters of xylene, cyclohexane and n-heptane are 18.2, 16.8 and 15.3  $\text{MPa}^{0.5}$  respectively, which is consistent with the order in which the rejection data appear in Figure 5 (i.e.  $\delta_{n\text{-heptane}} \approx \delta_{\text{PDMS}}$  to give the greatest swelling and lowest rejection) and also in agreement with the swelling data shown in Figure 3.

## Effects of Pressure and Solute Concentration

Figure 6 shows that solute rejection generally improves as filtration pressure increases and a similar trend was observed by the authors for many other solvent/solute/membrane combinations. The latter confirm the indications of Figure 5 where low-polarity solute rejection is uniquely dependent on the degree of solvent induced membrane swelling. Figure 6 shows that rejection is largely independent of solute concentration as values in the ppm range are unlikely to influence the degree of swelling. Solvent flux is likewise unaffected.

Figure 7 shows that at fixed crossflow and with a low polarity solvent and poly-nuclear aromatic (PNA) solute at 20 ppm concentration, the flux-pressure relationship is linear in accordance with Darcy's Law for all the tested membranes; it is noted that solute rejections increased over the same pressure range in accordance with the form of Figure 6. Several researchers have reported increasing solute rejection at raised pressures, frequently with obedience of Darcy's Law, whilst others have reported non-linear solvent flux/pressure relationships that has been attributed to

membrane compaction. Sufficient data have been acquired by the authors to suggest that the PDMS layers on composite membranes will generally undergo compression during pressure driven nanofiltration, particularly over the range 0-1000 kPa. However, the overall situation presents something of a paradox, how can increasing pressure, membrane compaction and increasing solute rejection occur simultaneously with a linear solvent flux-pressure relationship? Possibilities include:

1. The polymer chains move closer together under the raised pressure to reduce interstitial free volume, diffusional solute transport subsequently slows due to a reduced diffusion rate through the denser polymer and solute rejection progressively increases. Such an arrangement could reasonably be expected to also slow diffusional solvent transport and thus cause non-linearity of the flux-pressure relationship.
2. The polymer chains move further apart during swelling to allow a greater free volume in the membrane structure which tends to promote an element of convective flow and lower rejections. When the pressure is raised the reduction in free volume naturally brings polymer chains closer together to enhance rejection by a size exclusion mechanism. For this to happen simultaneously with a linear flux-pressure relationship, the free volume/flow paths in the PDMS would have to remain sufficiently large so as not to adversely affect flow.
3. A combination of (1.) and (2.).

Both (1.) and (2.) are beneficially influenced by the potential enhancements to transport due to the reduced PDMS thickness at raised pressure. That is, respectively, a shorter distance for molecules to diffuse through the membrane or a convective flux increase in accordance with Darcy's Law. There would need to be significant coincidence for the simultaneously acting factors to induce a linear solvent-flux relationship.

### Effects of Solute Size

Experiments with a range of PNA, organometallic and sulphur bearing solutes in xylene solvent are typical of those used to examine the influence of solute size. Referring to Figure 8, the data give a relatively sharp transition in rejection level over the size range 1-1.5 nm. Such behaviour is indicative of the selective PDMS layer rejecting low-polarity, minimally interacting solutes on the basis of size-exclusion. These data (and others) suggest a viscous solvent transport to an extent dependent on the degree of swelling induced change in the membrane free volume. A size-exclusion mechanism seems unlikely for dense membranes like PDMS as solute and solvent transport is intuitively diffusive. Although larger molecules can be expected to have very low diffusion rates, and thus high rejections, smaller molecules (<1 nm) would not be expected to give zero rejections as observed in Figure 8. At least three scenarios are possible:

- Solvent is transported via viscous flow and solute flux is diffusive (i.e. same rate)
- Solvent and solute fluxes both occur via a diffusive mechanism at identical rates
- Solvent and solute transport via a viscous flow mechanism at the same rate.

In the authors' opinion, the most feasible explanation is the latter where the solvent swells the membrane to effectively induce an ill-defined porous structure in the PDMS, and the zero rejections are due to the solvent and solute moving through the membrane structure 'as one' under viscous flow with no separation occurring. Very similar behaviour to that shown in Figure 8 was measured for a thermally crosslinked membrane, although higher rejection was recorded for a given solute due to reduced PDMS swelling, and also with an n-heptane solvent where rejections ~5% below those recorded for xylene were noted due to increased membrane swelling; such findings are in accordance with Figure 3.

It is recognised that the data in Figure 8 could be interpreted using solution-diffusion concepts as the solute diffusion coefficient will decrease with increasing solute size. Although this mechanism can't be completely dismissed, in the authors opinion the sharpness of the profile is more indicative of a size exclusion/sieving mechanism. Considerable coincidence would be required for the solute sorption and diffusion coefficients to align and produce the results shown. In Figure 8 it is likely that three distinct regions exist. In *Region A* the solvent induced swelling of the membrane causes sufficiently small solutes to translate directly with the solvent flow. In *Region C* the solute molecules are sufficiently large for high rejection to occur predominantly via a size exclusion mechanism. In *Region B* it is envisaged that a mixture of viscous flow and diffusion could exist. Modelling work by the authors supports these types of behaviour for membranes that swell significantly, although when more crosslinked PAN/PDMS membranes are considered the solution-diffusion model also appears to fit adequately.

### Effects of Solvent Polarity

Interpreting flux and rejection behaviour in crossflow nanofiltration becomes potentially more complex when polar solvents are considered. By way of example, whilst an xylene/ethanol feed mixture shows generally similar behaviour to that in Figures 6 and 7 where xylene flux increases with pressure as does ethanol rejection, Figure 9 infers a rather different rejection mechanism (i.e. one that is not based on solute size). Here, rejection data for 50 and 200 kGy radiation crosslinked membranes are largely superimposed over a wide range of ethanol concentrations which belies the difference in swelling propensity of the two membranes. Although Figure 4 infers that the overall degree of membrane swelling reduces with increasing ethanol concentration, the rejection of ethanol appears to be largely independent of the degree of crosslinking in the PDMS material. Interestingly, Figure 10 shows that the absolute component fluxes of xylene and ethanol were significantly different for each membrane sample but in similar ratios for a given ethanol concentration in the feed. The implication is that the overall degree of swelling affects both alcohol and xylene transport to the same degree which could be seen as evidence that there is little degree of separation during permeation through the depth of the membrane (i.e. coupled flows), and that the majority of the rejection occurs upon sorption into the PDMS layer.

### CONCLUSIONS

The rejection of low-polarity organic solute compounds from organic solvents has been shown to be dependent on solute size, hydrodynamic conditions, operating pressure and the swelling effect of the solvent. A hydrodynamic threshold exists, above which solute rejection plateaus. The concept of viscous flow is supported by the observation that the rejection of low-polarity solutes is predominantly one of size exclusion. Poor-swelling solvents yield a lower flux and higher solute rejection than good-swelling solvents. It is postulated that swelling increases the free volume within the membrane, which can be interpreted as an induced pore-like structure or raised porosity depending on the terminology used, and that the Hildebrand solubility parameter is a good indicator of swelling potential for PDMS membranes as well as a good predictor of their likely flux/rejection behaviour.

With non-polar/polar solvent mixtures and PAN/PDMS membranes preferential transport of the non-polar solvent occurs and the degree of rejection is dependent on the polarity of a solvent (e.g. alcohol) as quantified by its solubility parameter. Mixtures with  $15 < \delta < 19 \text{ MPa}^{0.5}$  do not separate, higher rejections are obtained with the components that exhibit higher values of  $\delta$ . The flux of each component in a mixture is affected by pressure, mixture composition and the degree of membrane swelling. Rejection is also affected by pressure and mixture composition but largely independent of the degree of membrane swelling. The latter suggests that rejection is primarily affected by multi-component swelling equilibria upon sorption into the selective layer.

## ACKNOWLEDGEMENTS

The authors would like to thank Shell Global Solutions and EPSRC for supplying project funding. GKSS Forschungszentrum are acknowledged for kindly supplying membranes.

## REFERENCES

1. Robinson J.P., Tarleton E.S., Millington C.R. and Nijmeijer A., 2004, Solvent flux through dense polymeric nanofiltration membranes, *J. Membrane Science*, **230**, 29-37.
2. Robinson J.P., Tarleton E.S., Millington C.R. and Nijmeijer A., 2004, Evidence for swelling-induced pore structure in dense PDMS nanofiltration membranes, *FILTRATION*, **4**(1), 50-56.
3. Tarleton E.S., Robinson J.P., Smith S.J. and Na J.J.W., 2005, New experimental measurements of solvent induced swelling in nanofiltration membranes, *J. Membrane Science*, **261**, 129-135.
4. Tarleton E.S., Robinson J.P., Millington C.R. and Nijmeijer A., 2005, Non-aqueous nanofiltration: Solute rejection in low-polarity binary systems, *J. Membrane Science*, **252**, 123-131.
5. Robinson J.P., Tarleton E.S., Ebert K., Millington C.R. and Nijmeijer A., 2005, Influence of cross-linking and process parameters on the separation performance of poly (dimethylsiloxane) nanofiltration membranes, *Industrial and Engineering Chemistry Research*, **44**(9), 3238-3248.
6. Tarleton E.S., Robinson J.P., Millington C.R., Nijmeijer A. and Taylor M., 2006, The influence of polarity on flux and rejection behaviour in solvent resistant nanofiltration – experimental observations, *J. Membrane Science*, **278**, 318-327.
7. Tarleton E.S., Robinson J.P. and Salman M., 2006, Solvent induced swelling of membranes – measurements and influence in nanofiltration, *J. Membrane Science*, **280**, 442-451.

## FIGURES AND TABLES

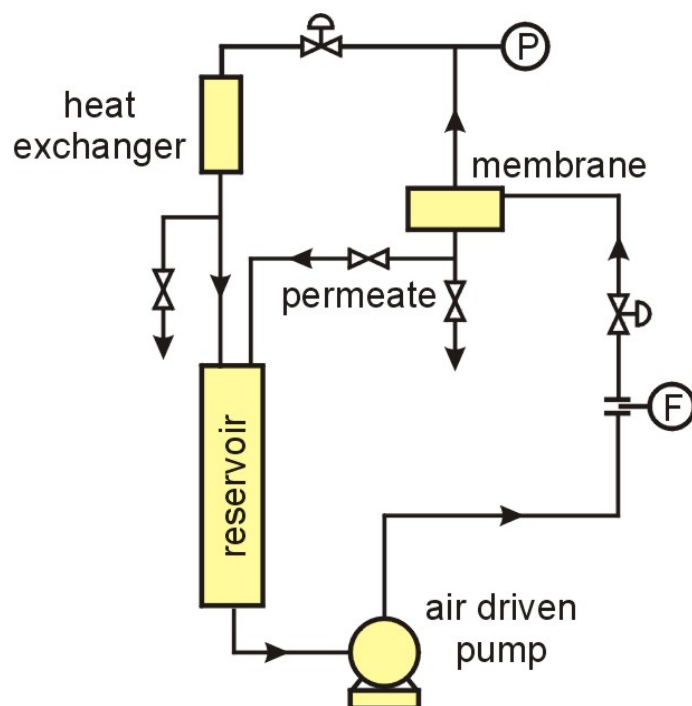

Figure 1: Schematic of crossflow nanofiltration apparatus.

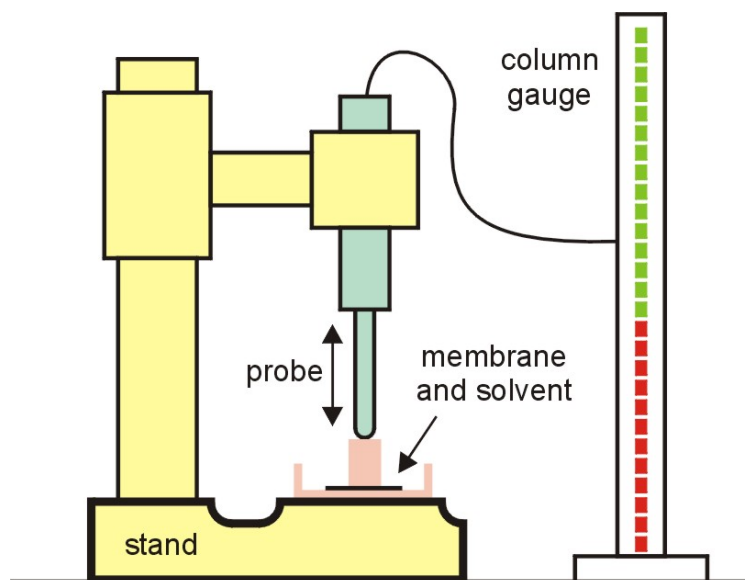

Figure 2: Schematic of membrane swelling apparatus.



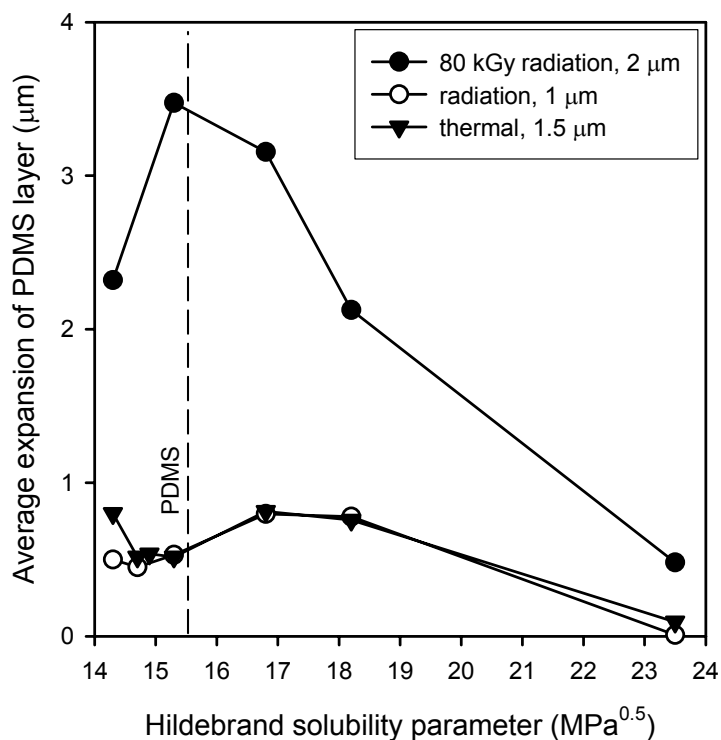

Figure 3: Swelling of three PAN/PDMS composite membranes in pure solvents.

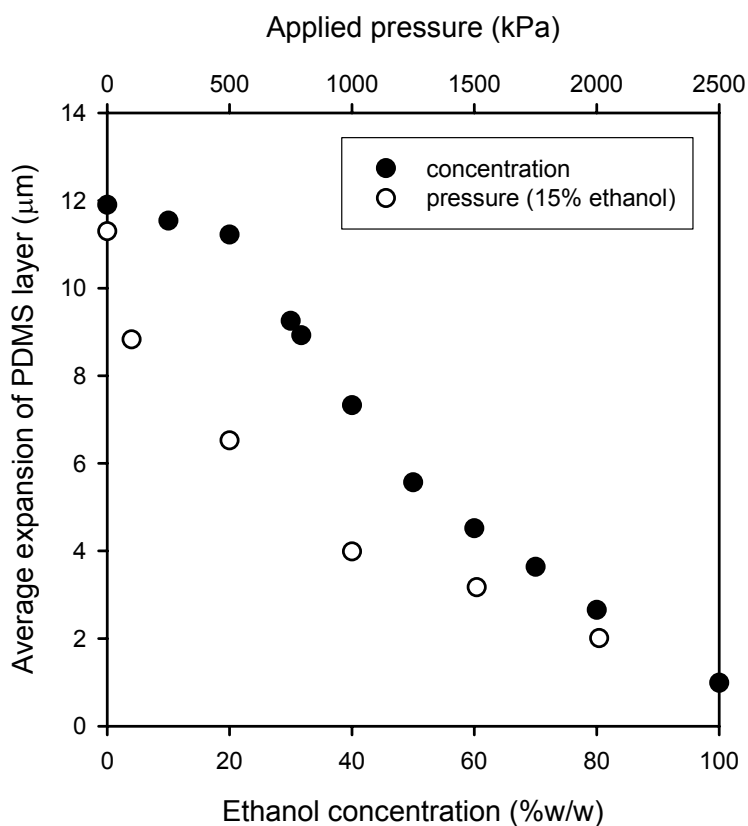

Figure 4: Typical influences of applied pressure and alcohol concentration on swelling for xylene/ethanol mixtures and a membrane with a 10 μm PDMS layer exposed to 80 kGy radiation.

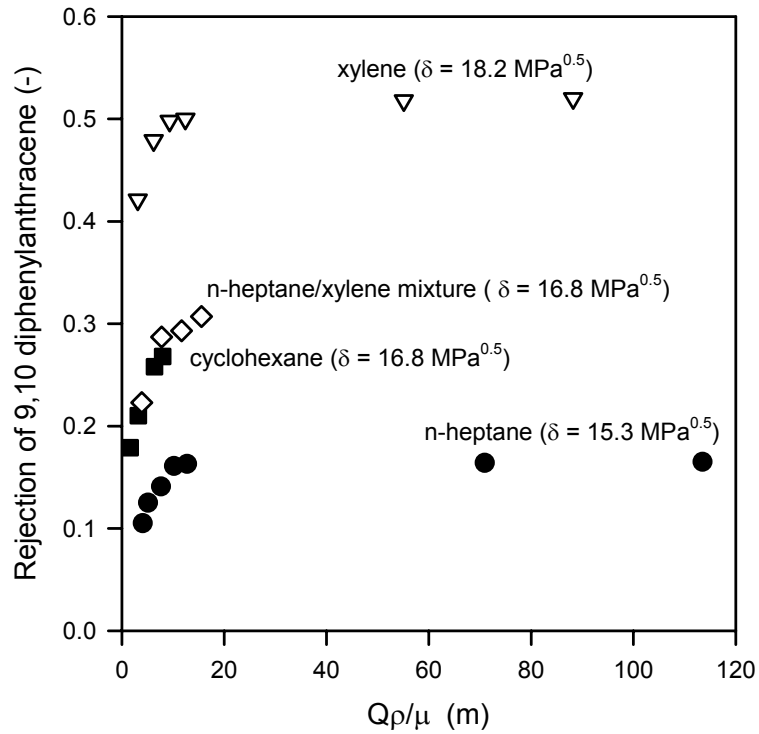

Figure 5: Effects of crossflow ( $Q\rho/\mu$ ) on rejection of 20 ppm solute from four solvents. 80 kGy radiation, 2  $\mu\text{m}$  membranes.

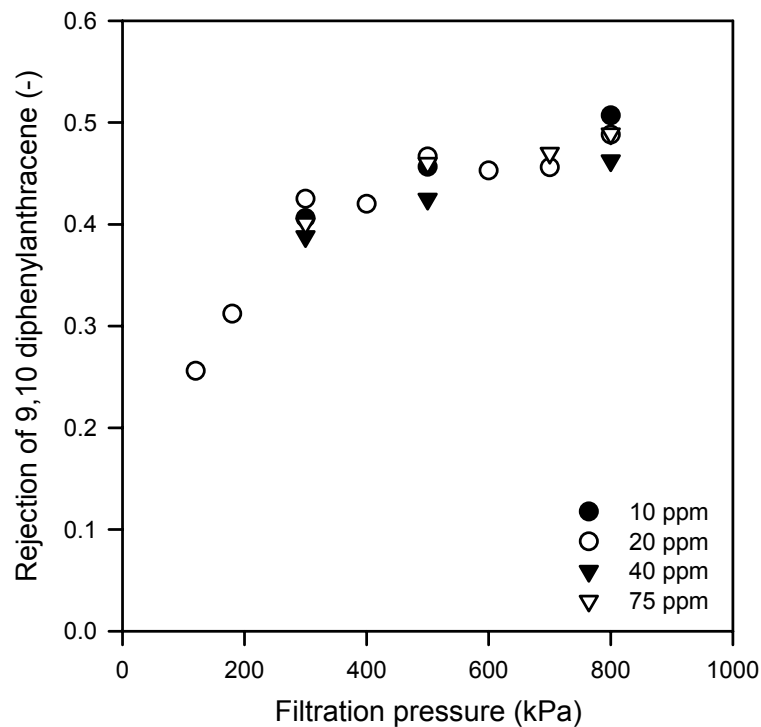

Figure 6: Effects of solute concentration/pressure on rejection from xylene. 80 kGy radiation, 2  $\mu\text{m}$  membranes.

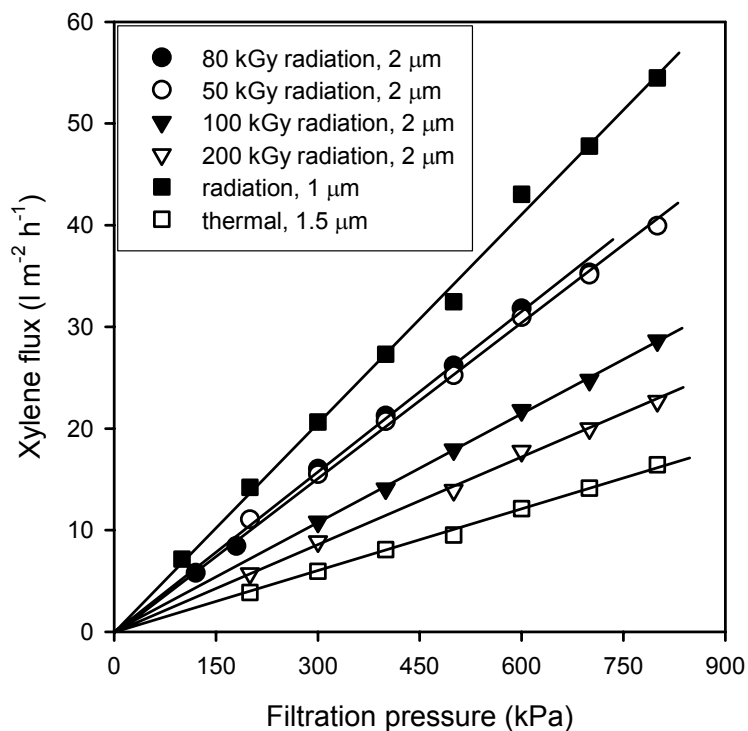

Figure 7: Flux-pressure relationships with xylene solvent for a range of PAN/PDMS composite membranes.

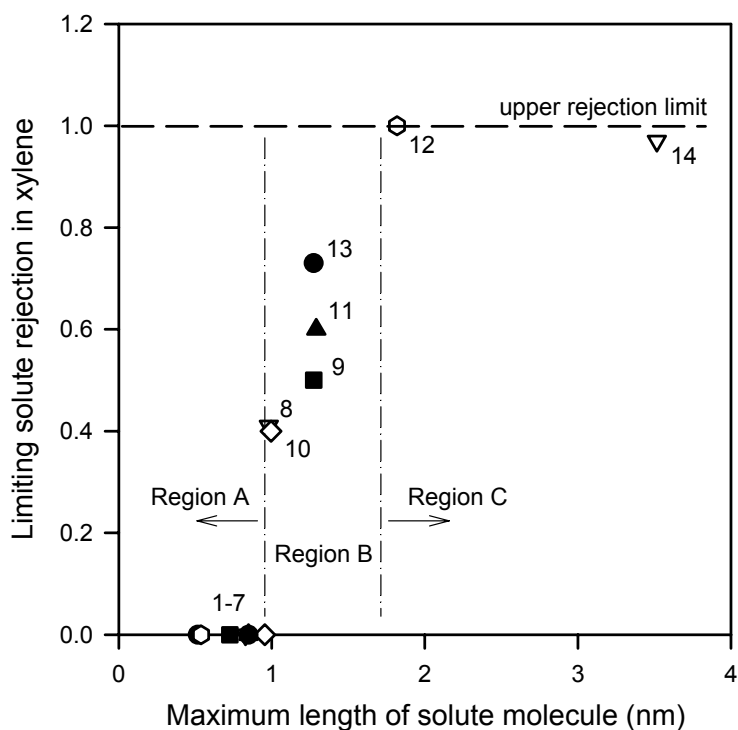

Figure 8: Effects of maximum solute dimension on rejection from a xylene solvent with a 80 kGy radiation, 2  $\mu\text{m}$  membrane.

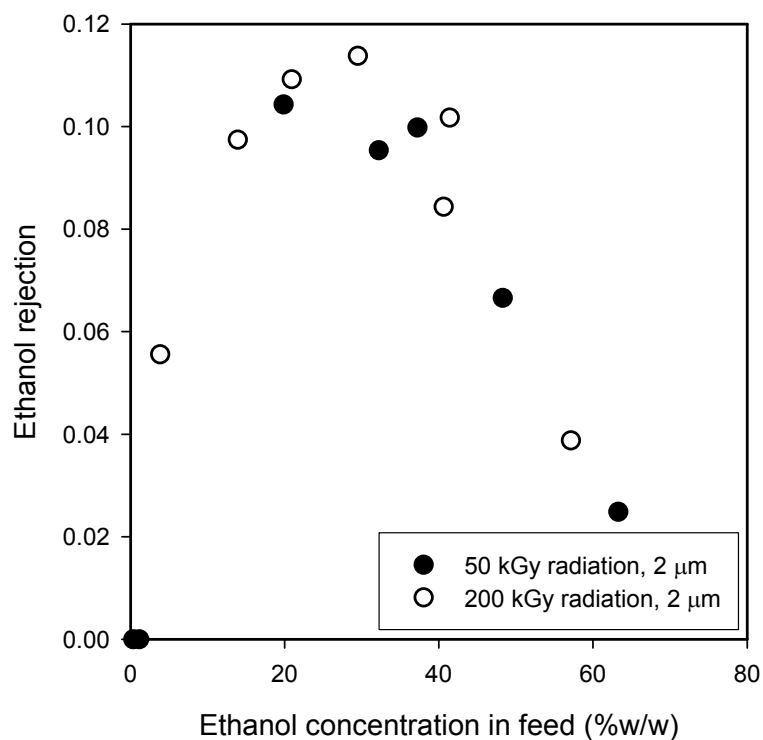

Figure 9: Ethanol rejection plotted against concentration for xylene/ethanol mixtures and two membrane variants with different degrees of radiation induced crosslinking.

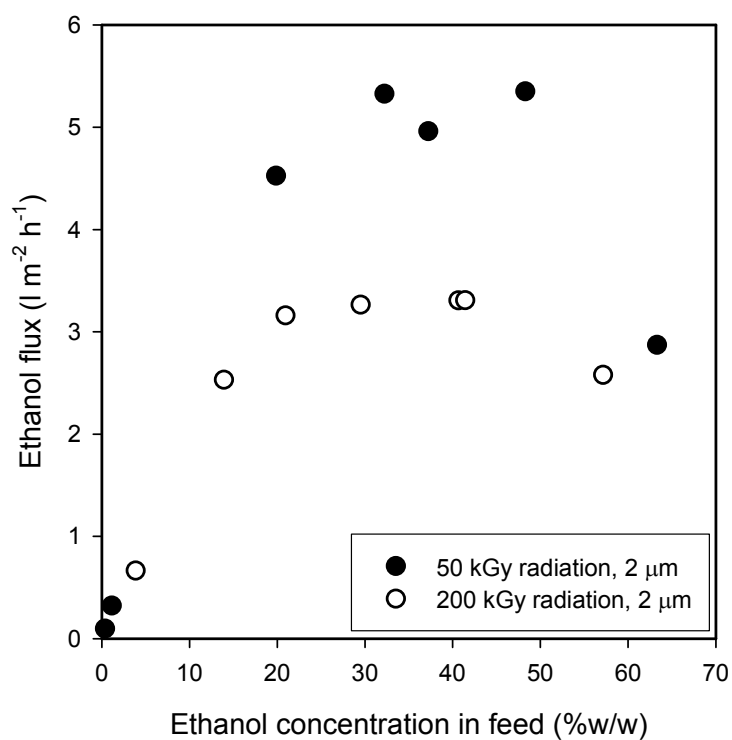

Figure 10: Ethanol flux plotted against concentration for xylene/ethanol mixtures and two membrane variants with different degrees of radiation induced crosslinking.